



BMW i Motorsport
Official Partner



PUMPING MADE EASY.
WATER TECHNOLOGY
FOR HOUSE AND GARDEN.



einhell.de





WATER TECHNOLOGY

All you need to know about pumps	3
Pump Advisor	3
The right Pump for the right Purpose	6
Pump Technology – Main Facts	8
Drainage – Submersible Pumps	10
Submersible pumps at a glance	10
Aqua Sensor Pumps	12
2-in-1 Multipurpose Pumps	14
For Environmental's Sake – Pump right.	17
ECO Submersible Pumps Dirty Water/Clear Water	18
Dirty Water Pumps	19
Rain Barrel Pump	22
Clear Water Pumps	23
Deep Well Pumps	24
Submersible Pressure Pumps	25

Watering – Surface Pumps	26
Surface Pumps at a glance	26
Cordless Garden Pump AQUINNA	28
Surface Pumps 'Plus'	30
Garden Pumps 'Plus'	34
Garden Pumps	36
Domestic Water Supplies – Service water in the house and garden	38
Automatic Home and Garden Pumps 'Plus'	38
Automatic Home and Garden Pumps	40
Water Works 'Plus'	42
Water Works	44
Petrol Water Pumps	46
Accessories	47
Petrol Water Pumps – Accessories Sets	47
Surface Pump Accessories	48
Which accessories go with which surface pump?	50
Service	52

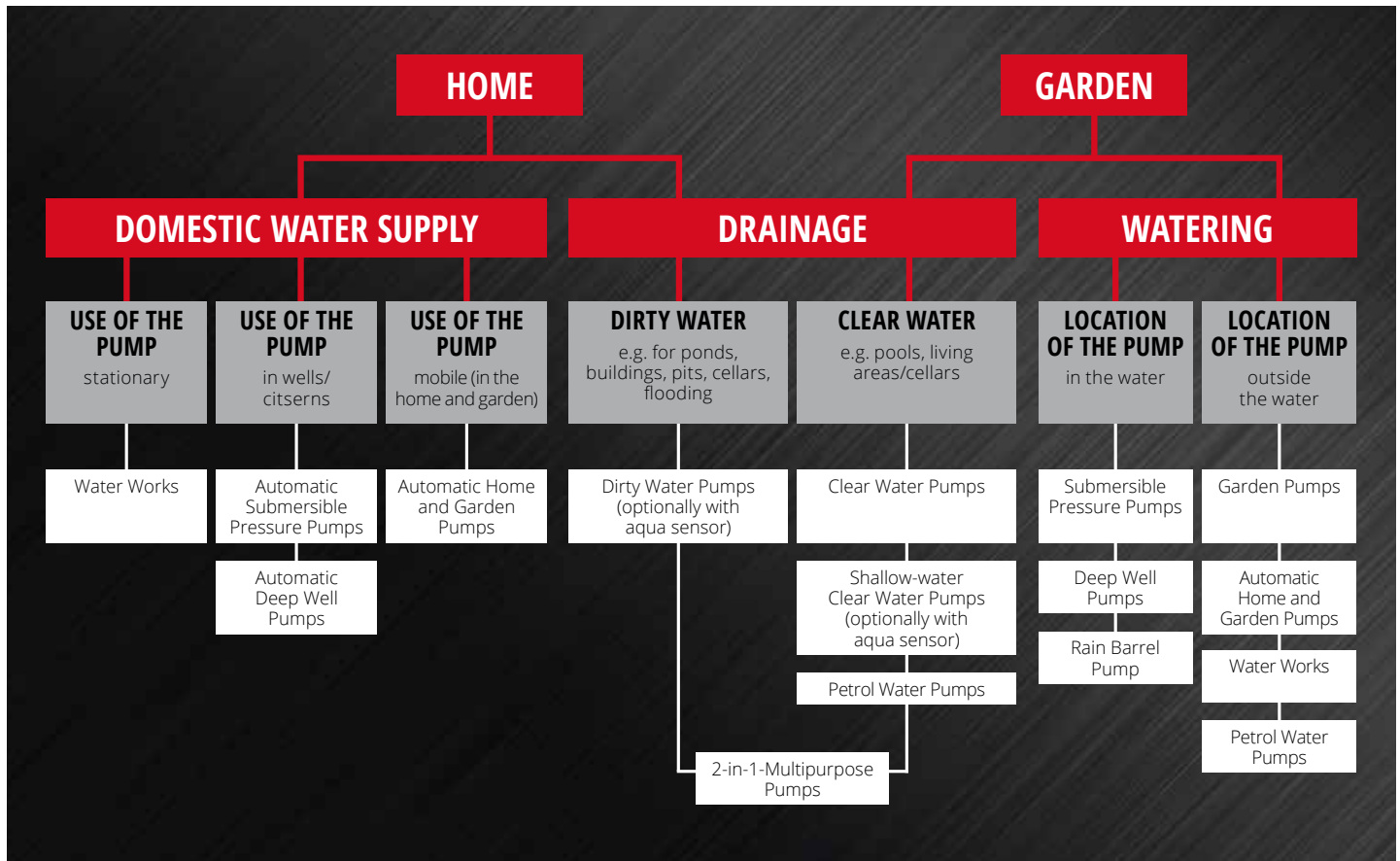



Powerful



Economical



Environmentally friendly



Versatile



DRAINAGE

Repumping/pumping out water – quicker and easier than ever. Pumping both clear water and dirty water with a high delivery rate is no problem with Einhell drainage pumps

- Uniform garden watering
- User-friendly and safe handling
- Conserves resources and saves drinking water



WATERING

To avoid wasting precious drinking water on watering the garden, alternative sources of water such as rainwater or water from cisterns can be used instead.

- Delivery of large quantities of water quickly
- Prevention of the worst water damage as far as possible by pumping out quickly
- High level of operational safety and reliability



DOMESTIC WATER SUPPLY

Fully automatic and with constant pressure. With the domestic water works, automatic home and garden pumps or automatic submersible pressure pumps from Einhell, you can put collected rainwater to use in the home, for example for toilet flushing, in your washing machine or for outdoor uses.

- Water supply for the home and garden from alternative water reservoirs (cisterns, wells)
- User-friendly and safe handling
- Conserves resources and saves drinking water



DRAINAGE



WATERING



DOMESTIC WATER SUPPLY

THE RIGHT PUMP FOR THE RIGHT PURPOSE.

Whether in the home or in the garden – Einhell has the right pump for every application:

1 | DEEP WELL PUMP

for watering the garden

» Read more on p. 25

2 | RAIN BARREL PUMP

for easy drawing of water from rainwater reservoirs

» Read more on p. 22

3 | MULTIPURPOSE PUMP / CLEAR WATER PUMP

for emptying pools

» Read more on pp. 14 - 15, p. 18 and p. 23

4 | POWER X-CHANGE CORDLESS GARDEN PUMP

for cordless garden watering

» Read more on p. 28 - 29

5 | SUBMERSIBLE PRESSURE PUMP

for watering the garden

» Read more on p. 24

6 | PETROL WATER PUMP

for watering the garden independently of the mains supply

» Read more on pp. 46

7 | DIRTY WATER PUMP / MULTIPURPOSE PUMP

for draining ponds

» Read more on pp. 14 - 15 and pp. 18 - 21

8 | GARDEN PUMP

for watering gardens from cisterns

» Read more on pp. 34 - 37

9 | AQUA SENSOR PUMP

for round-the-clock protection against flooding

» Read more on pp. 12 - 13

10 | AUTOMATIC WATER WORKS / WATER WORKS

for automatic domestic water supplies with service water

» Read more on pp. 38 - 45

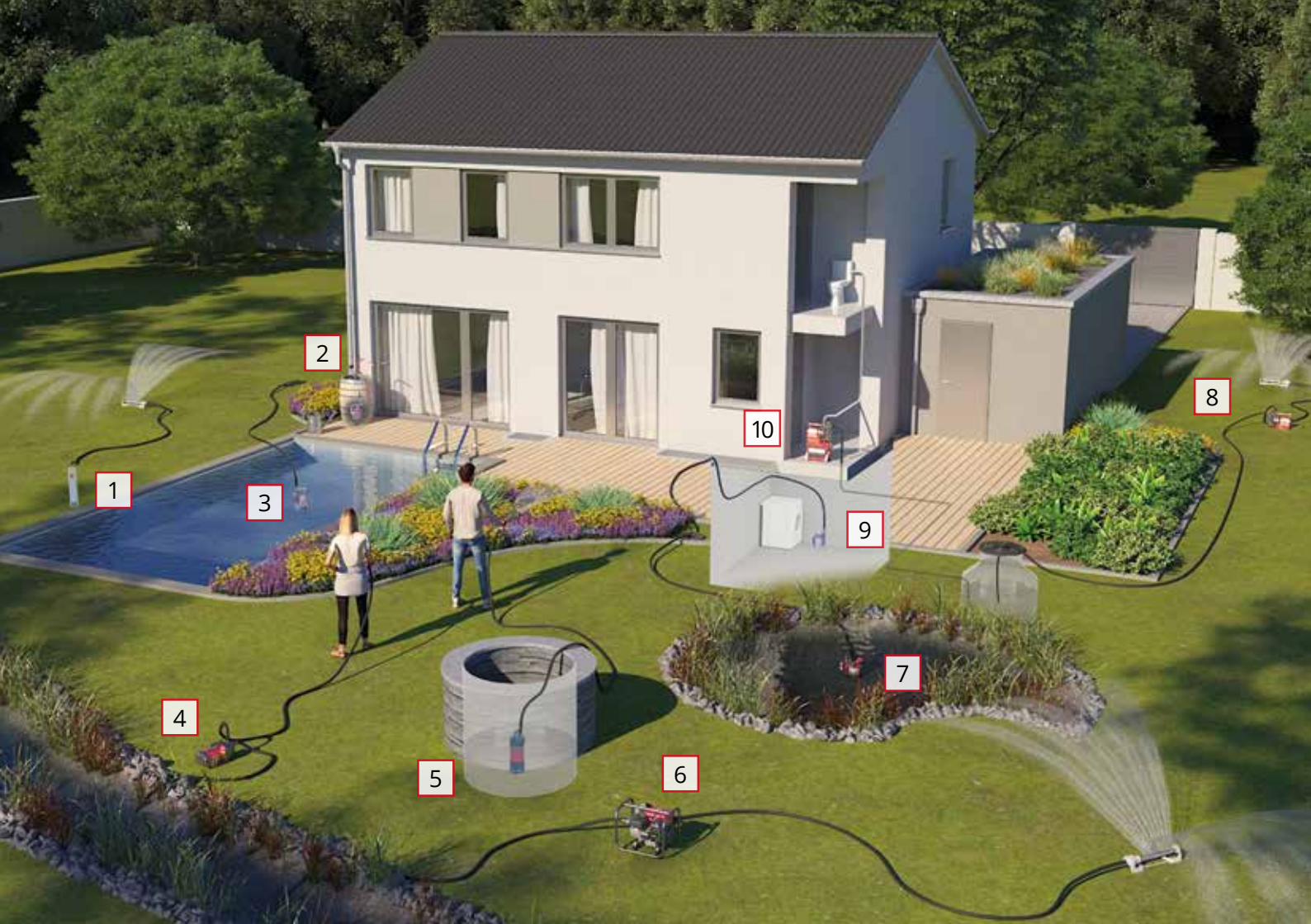

1

2

3

4

5

6

7

8

10

9



1

SUCTION HEIGHT

The suction height defines the height difference that can be overcome between the component at the heart of the pump, the paddle wheel, and the surface of the water. The suction capacity is based on the atmospheric air pressure under real conditions, as a result of which pumps generally face a physical limit of around 10 metres.

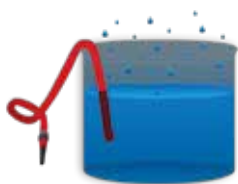

2

SERVICE WATER

Service water is water that is pumped by means of a pump from a well, shaft or cistern. Service water is not potable and must not be used for drinking water or for the preparation of food. In private households, service water can be used in separate outlets away from the drinking water supply as a supply for toilet flushing systems or washing machines, or as cleaning water.



3

DELIVERY PRESSURE

The delivery pressure describes the pressure with which the pump acts on the fluid being pumped. The higher the force of the pump used for pumping, the higher the pressure. Pressure is generally measured in bar, occasionally also in pascal. 100 kilopascal corresponds to a pressure of one bar.



4

DELIVERY HEAD

The delivery head describes the difference in height between the pump and the outlet of the water from the connected hose/sprinkler (caution: in the case of pumps that are submerged in water, the position of the pump is not used, but instead the height of the water surface).



5

DELIVERY RATE

The delivery rate, also referred to as the pumping capacity or suction capacity, describes the pumping capacity of a pump and is normally stated in 'liters per hour' (at Einhell). The delivery rate can also be described as a volumetric flow or flow rate, where the units 'cubic meters per second' are used.



6

CLEAR WATER

Clear water is slightly contaminated waste water with no particulate content. This includes waste water from personal hygiene, but not kitchen waste water, which is excluded because of the high levels of oils and bacteria from food waste. Clear water is not potable and must not be used for drinking water or for the preparation of food.

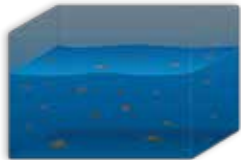

7

DIRTY WATER

Dirty water is the combined total of all waste water in the household and in commercial or agricultural operations, and it is heavily contaminated with bacteria. Dirty water must be purified via mechanical, chemical or biological means before it can be fed back into the water circuit.



8

PRE-FILTERS

Pre-filters prevent the ingress of contamination into the pump. Their use is always recommended if the pump is expected to pump water that may be contaminated and may contain sand or dirt particles.

SUBMERSIBLE PUMPS AT A GLANCE.

Whether for pumping out a flooded cellar or a construction pit, or for emptying pools or ponds – submersible pumps are the perfect aid. The main task of a submersible pump is to pump as much water as possible within the shortest possible time. The parameter that describes this ability is known as the delivery rate and is measured in liters/h.

Submersible pumps can be divided into two categories: Depending on the area of application and how clean the or dirty the water is that is to be pumped, you can choose either a clean water pump or a dirty water pump. But our range of submersible pumps also includes multitalents such as the 2-in-1 combination pumps for clean water and dirty water.

For more challenging tasks, such as pumping water from greater depths or under particularly high pressure, our deep well and submersible pressure pumps do a really fine job.



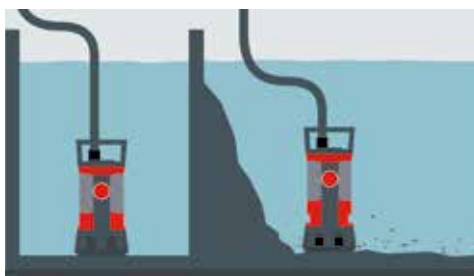

1

AQUA SENSOR PUMPS

Pump clean water or dirty water at any time thanks to the automatic sensor start function.



2

DIRTY WATER PUMPS

Quickly pump out dirty water from ponds, construction pits or cellars.

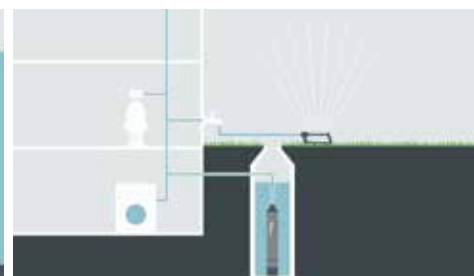

3

DEEP WELL PUMPS

For pumping water from particularly large depths for house and garden.

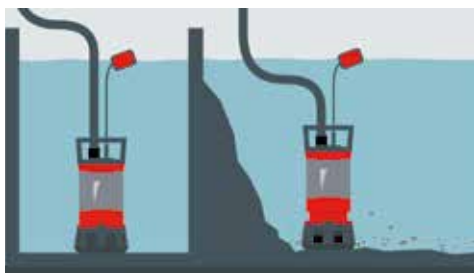

4

2-IN-1 MULTIPURPOSE PUMPS

Pump clean water and dirty water with the aid of the suction level adjustment.



5

CLEAR WATER PUMPS

Quickly pump out clean water from pools, living areas or cellars.

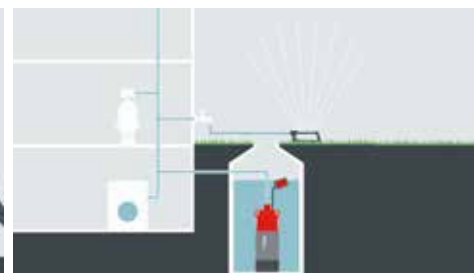

6

SUBMERSIBLE PRESSURE PUMPS

For pumping water to particularly great heights or under very high pressure for house and garden.

24/7 PROTECTION FROM FLOODS.

Thanks to our **aqua sensor technology**, the pumps operate with **patented** sensor adjustment at **three automatic starting heights** or can be used in continuous operation. Thanks to the integrated aqua sensor, the pumps offer a slimline design and can be used in narrow shafts.

Increased safety for your home so that you can enjoy your holiday without worries: The aqua sensor continuously monitors its environment and, depending on the model, sucks up the water until the surroundings can be wiped dry. This puts an end to unplanned, expensive surprises and provides you with immediate, **round-the-clock protection** – 24 hours a day, even when you are away.

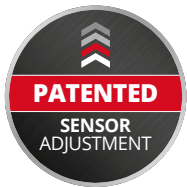

Clearly arranged adjustment of the three automatic sensor starting heights or the permanent mode.

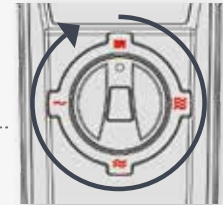
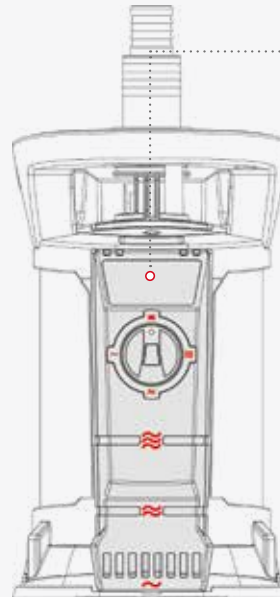

Permanent mode (ON/OFF) without using the sensor – pump start	
5 mm	50 mm
Automatic sensor start at	
103 mm	188 mm
Automatic sensor start at	
56 mm	135 mm
Automatic sensor start at	
5 mm	70 mm

AQUA SENSOR PUMPS (DIRTY WATER)

EXPERT

EXPERT

	GE-DP 7935 N-A ECO	GE-DP 6935 A ECO
Mains voltage	230 V ~ 50 Hz	230 V ~ 50 Hz
Rated input	790 W	690 W
Max. delivery capacity / height	19000 l/h / 9 m	17500 l/h / 9 m
Max. immersion depth	7 m	7 m
Max. size of foreign particle	35 mm	35 mm
Pump start during continuous operation	50 mm	50 mm
Sensor starting heights	70 mm / 135 mm / 188 mm	70 mm / 135 mm / 188 mm
Suction down to	40 mm	40 mm
Hose connection	47.8 mm (1½") ET	47.8 mm (1½") ET
Power cord	10 m	10 m
Product weight	6.2 kg	5.7 kg
Aqua Sensor Technology	•	•
Permanent mode without sensor start	•	•
Non-return valve	•	•
High-quality mechanical seal	•	•
Integrated cable rewind	•	•
Carry handle	•	•
Lifting eye	•	•
ECO Power	•	•
Universal hose adapter	•	•
Artikelnummer	41.714.60	41.714.50



4 006825 622287



4 006825 622270

AQUA SENSOR PUMPS (DIRTY WATER)

EXPERT

	GE-SP 4390 N-A LL ECO
Mains voltage	230 V ~ 50 Hz
Rated input	430 W
Max. delivery capacity / height	9000 l/h / 8 m
Max. immersion depth	7 m
Max. size of foreign particle	1 mm
Pump start during continuous operation	5 mm
Sensor starting heights	5 mm / 56 mm / 103 mm
Works in shallow clean water as low as	1 mm
Hose connection	47.8 mm (1½") ET
Power cord	10 m
Product weight	4.9 kg
Aqua Sensor Technology	•
Permanent mode without sensor start	•
Non-return valve	•
High-quality mechanical seal	•
Integrated cable rewind	-
Carry handle	•
Lifting eye	•
ECO Power	•
Universal hose adapter	•
Artikelnummer	41.714.40



4 006825 622263

OUR ALL-ROUNDERS.

The **2-in-1 multipurpose pumps** from Einhell are robust, powerful and reliable aids for pumping out ponds, construction pits and flooded cellars quickly and energy-efficiently, as well as for many other drainage tasks.

Two genuine all-rounders: With the patented suction level adjustment, a simple rotary motion on the foot of the pump allows the unit to be quickly adapted to the required function (clean water mode or dirty water mode) – providing users with a combination pump for two different tasks: for shallow-water applications down to a residual water layer depth of 1 mm in clean water mode (meaning, for example, that a cellar can then simply be wiped dry) or for sucking up dirty water containing dirt particles with a size of up to 30 mm.



2-IN-1 MULTIPURPOSE PUMPS

EXPERT

EXPERT

	GE-DP 7330 LL ECO	GE-DP 5220 LL ECO
Mains voltage	230 V ~ 50 Hz	230 V ~ 50 Hz
Rated input	730 W	520 W
Max. delivery capacity / height	16500 l/h / 8.5 m	13500 l/h / 7.5 m
Max. immersion depth	7 m	7 m
Max. size of foreign particle	30 mm	20 mm
Works in shallow clean water as low as	1 mm	1 mm
Starting of pump from water level of	10 mm	10 mm
Hose connection	47.8 mm (1½") ET	47.8 mm (1½") ET
Power cord	10 m	10 m
Product weight	6.2 kg	5.4 kg
Patented suction level control	•	•
High-quality mechanical seal	•	•
Floating switch (automatic and manual mode)	•	•
Integrated cable rewind	•	•
ECO Power	•	•
Carry handle with integrated lifting eye	•	•
Universal hose adapter	•	•
Artikelnummer	41.707.90	41.707.80



4 006825 598827



4 006825 598780



FOR ENVIRONMENTAL'S SAKE – PUMP RIGHT.

Water is one of the most valuable resources we have. It is high time we optimise our consumption. Especially in summer. The large quantities of water we need for our garden quite often come straight from the water mains. It is more environmentally friendly to use natural rain water or ground water, either from cisterns, wells or rainwater tanks.

Einhell water pumps help you use these natural sources in an efficient and sustainable manner. Whether it is a garden pump to water your plants or a domestic water supply system for the flushing toilets etc.: The Einhell pump advisor will find the right pump that meets your requirements.

WHERE TECHNICAL EXPERTISE AND ENHANCED ENVIRONMENTAL PROTECTION MEET



Each of us is responsible for the environment in which we live. Even as individuals, we have an important role to play. Our contribution: expertise and technology for efficient resource utilization. ECO Power stands for the use of efficient technology.

For example, our ECO Pumps feature the latest advances in technology which appreciably improve the energy-to-performance output ratio.



PERFECT FLOW GEOMETRY

An optimised hydrodynamic flow duct reduces the flow resistance and 4100 l/h enables powerful, obstruction-free pumping of the water.



OPTIMISED IMPELLER

The optimised impeller with modified vane geometry ensures perfect flow characteristics. Powerful, fault-free operation, maximum flow rate and minimal electricity consumption are thus possible.



HIGH-GRADE MECHANICAL SEAL

In contrast to standard pump seals (shaft seals), we have designed high-grade mechanical seals into our ECO Power dirty water pumps to reduce friction and wear even in demanding conditions. The pumps last longer, reducing both resource consumption and the impact on the environment.

SUBMERSIBLE PUMPS DIRTY/CLEAR WATER 'ECO'



	GE-DP 7935 N ECO	GE-DP 6935 ECO	GE-DP 3925 ECO	GE-SP 4390 LL ECO
Suitable for	Dirty water	Dirty water	Dirty water	Clear water
Mains voltage	230 V ~ 50 Hz	230 V ~ 50 Hz	230 V ~ 50 Hz	230 V ~ 50 Hz
Rated input	790 W	690 W	390 W	430 W
Max. delivery capacity / height	20000 l/h / 9 m	17500 l/h / 9 m	10000 l/h / 6 m	9000 l/h / 8 m
Max. immersion depth	7 m	7 m	7 m	7 m
Min. water level for pump start	50 mm	50 mm	50 mm	5 mm
Works in shallow clean water as low as	-	-	-	1 mm
Max. size of foreign particle	35 mm	35 mm	25 mm	1 mm
Hose connection	47.8 mm (1½") ET	47.8 mm (1½") ET	47.8 mm (1½") ET	47.8 mm (1½") ET
Power cord	10 m	10 m	10 m	10 m
Product weight	7.3 kg	5.5 kg	4.5 kg	4.5 kg
Integrated lifting eye	•	•	•	•
High-quality mechanical seal	•	•	•	•
Floating switch (automatic and manual mode)	•	•	•	•
Integrated cable rewind	•	•	•	-
ECO Power	•	•	•	•
Carry handle	•	•	•	•
Non-return valve	-	-	-	•
Universal hose adapter	•	•	•	•
Artikelnummer	41.707.00	41.707.20	41.707.10	41.707.15



OUR HEAVYWEIGHTS.

Thanks to the extremely durable pump housing made of corrosion-resistant stainless steel and cast metal (depending on the model), the pumps can reliably withstand even the harshest levels of use. In addition, sturdy cast metal parts are provided on some of our models to provide them with a particularly secure and stable footing, particularly in very dirty water.

DIRTY WATER PUMPS



CLASSIC



CLASSIC



CLASSIC

	GC-DP 1340 G	GC-DP 5010 G	GC-DP 9035 N
Mains voltage	230 V ~ 50 Hz	220 - 240 V ~ 50 Hz	220 - 240 V ~ 50 Hz
Rated input	1300 W	500 W	900 W
Max. delivery capacity / height	23000 l/h / 10 m	12000 l/h / 8 m	18000 l/h / 9 m
Max. immersion depth	5 m	5 m	5 m
Max. size of foreign particle	40 mm	10 mm	35 mm
Hose connection	59.6 mm (2") IT	42 mm (1 1/4") IT	47.8 mm (1 1/2") IT
Power cord	10 m	10 m	10 m
Product weight	22.0 kg	10.6 kg	5.95 kg
Integrated lifting eye	-	-	-
High-quality mechanical seal	•	•	•
Floating switch	Automatic mode	Automatic mode	Automatic and manual mode
Integrated cable rewind	-	-	-
ECO Power	-	-	-
Carry handle	•	•	•
Universal hose adapter	•	•	•
Lowering rope	• (6 m)	-	-
Artikelnummer	41.707.42	41.714.21	41.707.78



OUR COMPACT HELPERS.

Robust, powerful and extremely reliable helpers for pumping out construction pits, wells and other very dirty bodies of water.

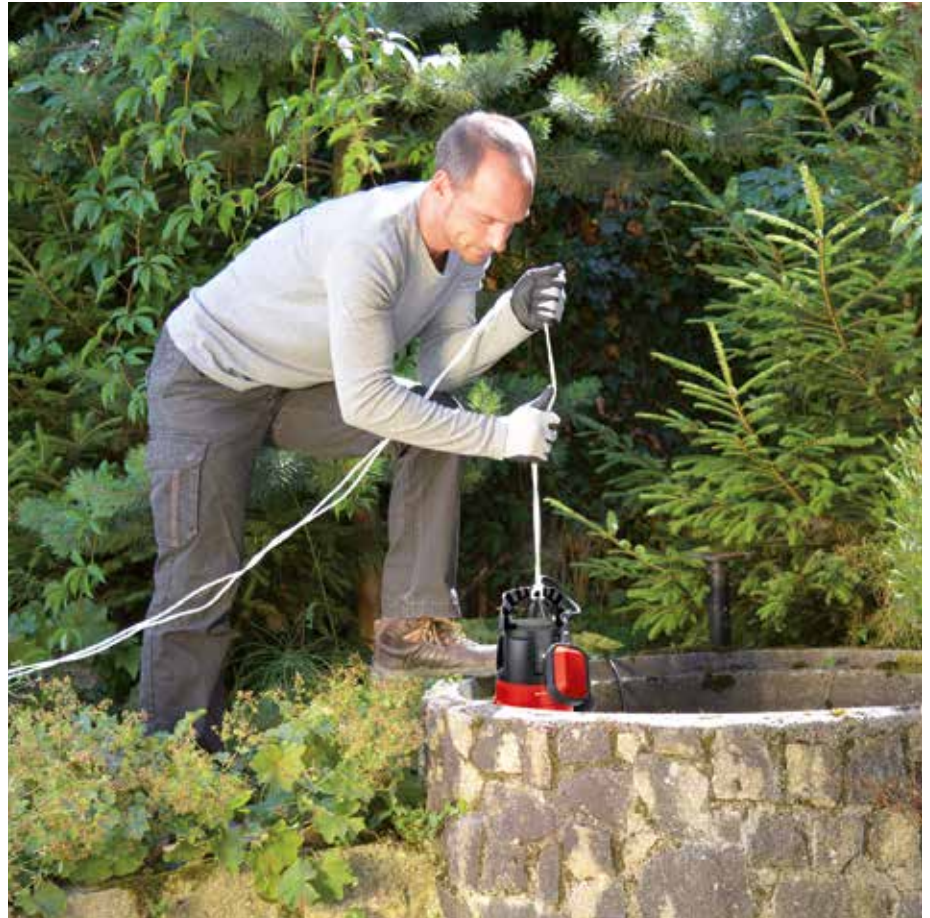

DIRTY WATER PUMPS



CLASSIC



CLASSIC



CLASSIC



CLASSIC

	GC-DP 7835	GC-DP 6315 N	GC-DP 5225 N	GC-DP 3730
Mains voltage	230 V ~ 50 Hz	230 V ~ 50 Hz	230 V ~ 50 Hz	230 V ~ 50 Hz
Rated input	780 W	630 W	520 W	370 W
Max. delivery capacity / height	15700 l/h / 8 m	17000 l/h / 8 m	10000 l/h / 7 m	9000 l/h / 5 m
Max. immersion depth	7 m	5 m	5 m	5 m
Max. size of foreign particle	35 mm	15 mm	25 mm	30 mm
Hose connection	47.8 mm (1½") IT	47.8 mm (1½") IT	47.8 mm (1½") IT	47.8 mm (1½") IT
Power cord	10 m	10 m	10 m	10 m
Product weight	5.2 kg	4.7 kg	4.1 kg	4.3 kg
Integrated lifting eye	-	-	-	-
High-quality mechanical seal	•	•	•	•
Floating switch (automatic and manual mode)	•	•	•	•
Integrated cable rewind	•	•	•	•
ECO Power	-	-	-	-
Carry handle	•	•	•	•
Universal hose adapter	•	•	•	•
Lowering rope	-	-	-	-
Artikelnummer	41.706.82	41.704.91	41.704.81	41.704.71



THE PRACTICAL RAIN BARREL PUMP.

High-quality, reliable and efficient helper which was designed specially for drawing water from rain barrels and cisterns. An infinitely variable float switch can be used to set this robust pump to continuous operation or to a specific ON and OFF switching level. The pump has a flexible swan-neck with stopcock for individual positioning of the garden hose, as well as a rain barrel bracket for securing the pump to the barrel itself.



RAIN BARREL PUMP



	GE-SP 3546 RB
Mains voltage	230 V - 50 Hz
Rated input	350 W
Max. delivery capacity / height	4600 l/h / 11 m
Max. immersion depth	7 m
Max. size of foreign particle	2.5 mm
Hose connection	26.4 mm (¾") ET
Power cord	10 m
Suction down to	-
Product weight	5.0 kg
High-quality mechanical seal	-
Floating switch (infinitely variable)	•
Integrated cable rewind	•
Carry handle	•
Flexible gooseneck	•
Storage compartment for extensions	•
Universal hose adapter	-
Artikelnummer	41.704.38



FLEXIBILITY FOR CLEAR WATER APPLICATIONS.

Ideal for drainage, removal and transportation of clean and slightly soiled water.

CLEAR WATER PUMPS

**EXPERT****CLASSIC****CLASSIC****CLASSIC**

	GE-SP 750 LL	GC-SP 5511 IF	GC-SP 3580 LL	GC-SP 2768
Mains voltage	230 V ~ 50 Hz	230 V ~ 50 Hz	230 V ~ 50 Hz	230 V ~ 50 Hz
Rated input	750 W	550 W	350 W	270 W
Max. delivery capacity / height	15000 l/h / 10 m	11000 l/h / 8.5 m	8000 l/h / 7.5 m	6800 l/h / 5.5 m
Max. immersion depth	5 m	7 m	7 m	5 m
Hose connection	42 mm (1¼") ET	47.8 mm (1½") IT	47.8 mm (1½") IT	47.8 mm (1½") IT
Power cord	10 m	10 m	10 m	10 m
Min. water level for pump start	50 mm	60 mm	8 mm	-
Suction down to	2 mm	5 mm	1 mm	8 mm
Product weight	6.2 kg	4.4 kg	3.1 kg	3.9 kg
High-quality mechanical seal	•	-	•	•
Integ. float switch (auto. + manual mode)	•	•	•	•
Integrated cable rewind	•	-	•	•
Carry handle	•	•	•	•
Universal hose adapter	•	•	•	•
Artikelnummer	41.706.66	41.704.63	41.704.45	41.704.42



WATER POWER FOR HOUSE AND GARDEN.

If you need to pump water to particularly great heights or under very high pressure, then our submersible pressure pumps offer just the support you need.

Now also with automatic power to even greater heights: After even more user-friendliness? Thanks to the automatic function, the GE-PP 1100 N-A automatically switches on when a water demand is present and then off again. This also makes it well suited for domestic water supplies.



SUBMERSIBLE PRESSURE PUMPS



EXPERT



CLASSIC

	GE-PP 1100 N-A	GC-DW 900 N
Mains voltage	220 - 240 V ~ 50 Hz	230 V ~ 50 Hz
Rated input	1100 W	900 W
Max. delivery capacity / height	6000 l/h / 45 m	6000 l/h / 32 m
Max. immersion depth	12 m	7 m
Max. size of foreign particle	-	2.5 mm
Hose connection	33.3 mm (1") IT	33.3 mm (1") IT
Power cord	15 m	10 m
Product weight	8.7 kg	8.9 kg
Automatic mode	•	-
Floating switch	Automatic and manual mode	Automatic mode
Dry operation protection	•	-
Multi-stage pump impeller	• (4 pcs)	• (3 pcs)
High-quality mechanical seal	•	•
Overload cut-out	•	•
Integrated non-return valve	•	-
Stainless dirt screen	•	-
High-quality INOX housing	•	•
Artikelnummer	41.714.30	41.709.64



WATER SUPPLY FROM DEEP RESERVOIRS.

The two deep well pumps GC-DW 1300 N and GC-DW 1000 N are hugely powerful and reliable units for pumping water from particularly low-lying reservoirs, wells or shafts. The sturdy pump housings are made of corrosion-resistant stainless steel and are thus extremely durable. The robust pressure connection is equipped with a brass insert and thus ensures a longer service life for the connecting thread.



DEEP WELL PUMPS



	NEW	EXPERT	CLASSIC	CLASSIC
	GE-DW 1100 N-A	GC-DW 1300 N	GC-DW 1000 N	
Mains voltage	220 - 240 V ~ 50 Hz	230 V ~ 50 Hz	220 - 240 V ~ 50 Hz	
Rated input	1100 W	1300 W	1000 W	
Max. delivery capacity / height	6000 l/h / 55 m	5000 l/h / 65 m	6500 l/h / 45 m	
Max. immersion depth	19 m	20 m	19 m	
Max. size of foreign particle	-	-	-	
Hose connection	33.3 mm (1") IT	47.8 mm (1½") IT	42 mm (1¼") IT	
Power cord	22 m	2 m / 23 m	22 m	
Pump diameter	99 mm	102 mm	98 mm	
Product weight	9.81 kg	15.5 kg	7.7 kg	
Automatic mode	•	-	-	
Dry operation protection	•	-	-	
Multi-stage pump impeller	• (8 pcs)	• (10 pcs)	• (6 pcs)	
High-quality mechanical seal	•	•	•	
Overload cut-out	•	•	•	
Integrated non-return valve	•	•	•	
Stainless dirt screen	•	•	•	
High-quality INOX housing	•	•	•	
External switchbox	-	•	-	
Lowering rope	• (22 m)	• (20 m)	• (22 m)	
Artikelnummer	41.709.35	41.709.44	41.709.55	



SURFACE PUMPS AT A GLANCE.

No matter whether for watering tasks in the garden or for domestic water supplies – Einhell surface pumps like garden pumps, automatic home and garden pumps, domestic water works or petrol water pumps are perfectly equipped for these challenges. Thanks to the high delivery pressure, high delivery heads or long delivery distances can be easily overcome.

With garden pumps or automatic home and garden pumps, groundwater can be pumped efficiently and safely for the environment from wells or cisterns and easily used to water the garden.

Fully automatic and with constant pressure with Einhell domestic water works and automatic home and garden pumps you can use collected service water in the home, for example to flush the toilet or in your washing machine. And if no power supply is available, the range of cordless or petrol water pumps from Einhell is on hand to deliver pumping capability in any location.





1

GARDEN PUMPS

For watering the garden.



2

AUTOMATIC HOME AND GARDEN PUMPS

For automatic garden watering and domestic water supplies.



3

WATER WORKS

For automatic domestic water supplies or garden watering.



4

PETROL WATER PUMPS

For watering and drainage tasks – independently of the mains power supply.



POWER X-CHANGE GARDEN PUMP.

POWER X-CHANGE

The Einhell AQUINNA Power X-Change garden pump leaves nothing to be desired when it comes to cordless freedom. Whether for working in your allotment, on a camping trip or if the nearest socket outlet in the garden is simply too far away – no problem for the compact and user-friendly AQUINNA. It can be quickly transported from A to B and has 36 V (2 x 18 V) of power to deliver up to 3,000 liters per hour at up to 2.8 bar. Where less pressure might occasionally be required, a 2-level switch enables it to be easily switched to ECO mode, doubling the running time at the same time.



POWER X-CHANGE

CORDLESS GARDEN PUMP

AQUINNA
36 V
POWER
 2 x 18 V

NEW
EXPERT PLUS

	AQUINNA
PXC battery voltage / capacity	2x 18 V / -
Charging time	-
Max. running time	-
Max. delivery capacity / height	3000 l/h / 26 m
Max. suction height	6 m
Suction connection	42 mm (1½") ET
Pressure connection	33.3 mm (1") IT
Product weight	3.3 kg
Water filler screw	•
Frost protection due to a water drain screw	•
2-step ECO switch	•
Carry handle	•
Artikelnummer	41.804.00



4 006825 638981



SURFACE PUMPS 'PLUS'

EASY PUMPING. WITH THE NEW SURFACE PUMP GENERATION FROM EINHELL.

Fast and easy installation as well as quick error detection thanks to **status indicators**.

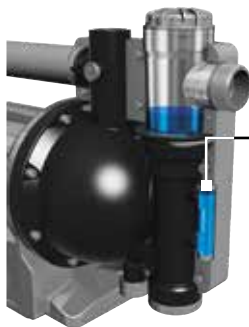

EXPERT Version

WATER FILLING INDICATOR

Before starting-up the pump for the first time it needs to be filled with water to secure a flawless intake procedure. Thanks to the sight glass the customer can see at first sight if there is already enough water filled into the pump.



CLASSIC Version



VORFILTER

Einfach herausnehmbar zur Reinigung oder Auswechslung.



SUCTION INDICATOR

A pressure gauge in the cover of the water filling opening continuously shows the current suction pressure and the suction height.

BIG WATER FILLER SCREW

Big water filler opening through which it is very easy to fill water into the pump.

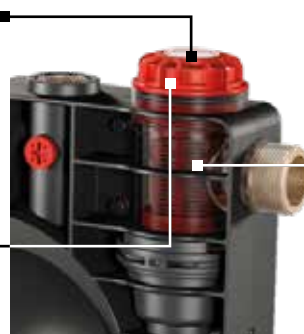

DIRT INDICATOR

Thanks to the transparent housing surrounding the coarse filter, it is easy to see whether the filter is dirty and may need cleaning.

SCALDING PROTECTION

If there is a blockage on the pressure side and the pump continues working, the water that remains in the pump will get hot. To prevent the customer from scalding himself with the hot water when checking the pump, the scalding protection shuts off the pump when the sensor recognizes too high temperature inside of the pump.

DRY RUNNING PROTECTION

If the pump is not able to suck water any more (e.g. empty water source) the dry running safety recognizes this and stops the pump. It tries to start the pump again and if there is still no water getting sucked it stops again and shuts off the pump. This prevents overheating of the pump and so a overheating of the engine.

SURFACE PUMPS 'PLUS'

Long life, low maintenance and exceptional **protection** thanks to special **safety mechanisms**.

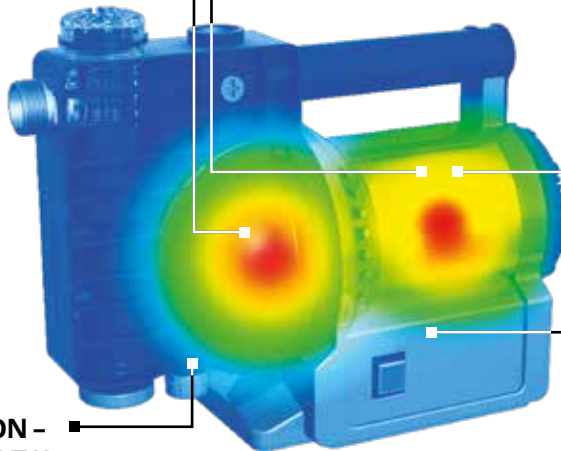

FROST PROTECTION – WATER DRAIN SCREW

Often customers forgets to empty the pump before winter and the frozen water destroys the pump. To hinder the water to freeze there is a convenient water drain screw with which the water can be released very quick.

THERMO PROTECTION

To prevent severe damages, the integrated thermo switch cuts off the pump when the engine overheats.

WATER FLOW RECOGNITION SENSOR

Sensor that measures the water flow (LEDs).

- Green: Pump runs normal
- Yellow: Less water in the pump
- Red: No water in the pump

SURFACE PUMPS 'PLUS'

FEATURE SEGMENTATION		
	EXPERT	CLASSIC
Garden Pumps	GE-GP 1145 ECO GE-GP 1246 N FS	GC-GP 6040 ECO GC-GP 8042 ECO GC-GP 1045 GC-GP 1250 N
Automatic Home and Garden Pumps	GE-AW 1042 FS GE-AW 1246 N FS	–
Water Works	GE-WW 1145 ECO GE-WW 1246 N FS	GC-WW 8042 ECO GC-WW 1045 N
STATUS INDICATORS		
Water Filling Indicator	•	•
Suction Indicator	•	–
Dirt Indicator (Pre-filter with non-return valve)	•	–
SAFETY + PROTECTION		
Water Flow Recognition Sensor	• (except GE-GP/WW 1145 ECO)	–
Dry Running Protection	• (except GE-GP/WW 1145 ECO)	–
Scalding Protection	• (except GE-GP/WW 1145 ECO)	–
Thermo Protection	•	•
Frost Protection	•	•



GARDEN PUMPS 'PLUS'

Einhell garden pumps Plus have innovative features to make them even more user-friendly than previous garden pumps.

Starting up and troubleshooting are even easier than ever before thanks to innovative status indicators such as suction, dirt and water filling indicators. For a long service life, low maintenance and exceptional protection, some models have special safety mechanisms such as the flow sensor, dry running protection, scalding protection and frost protection. But every model has a thermo switch for protection against damage caused by overheating of the engine.

GARDEN PUMPS ,PLUS'



Mains voltage / rated input	GE-GP 1246 N FS 220 - 240 V ~ 50 Hz / 1200 W	GE-GP 1145 ECO 220 - 240 V ~ 50 Hz / 1100 W
Max. delivery capacity / height	4600 l/h / 50 m	4500 l/h / 48 m
Max. suction height	8 m	8 m
Suction connection / pressure connection	42 mm (1 1/4") ET / 33.3 mm (1") IT	42 mm (1 1/4") ET / 33.3 mm (1") IT
Additional pressure connection	33.3 mm (1") IT	33.3 mm (1") IT
Power cord	1.5 m	1.5 m
Product weight	13.0 kg	13.0 kg
Carry handle	Comfort	Comfort
Water filler screw	•	•
Prefilter with integrated non-return valve	•	•
Frost protection due to a water drain screw	•	•
Indicator	LED	-
Water filling / dirt / suction indicator	• / • / •	• / • / •
Thermo / scalding protection	• / •	• / -
Dry running protection	•	-
Water flow recognition sensor	•	-
ECO Power	-	•
Artikelnummer	41.803.60	

SPRING
2020

NEW

EXPERT



SPRING
2020

NEW

EXPERT



4 006825 640366

Article number and +
EAN code not yet specified.

GARDEN PUMPS ,PLUS'



NEW

CLASSIC



NEW

CLASSIC



NEW

CLASSIC



NEW

CLASSIC

	GC-GP 1250 N	GC-GP 1045	GC-GP 8042 ECO	GC-GP 6040 ECO
Mains voltage / rated input	220 - 240 V ~ 50 Hz / 1200 W	220 - 240 V ~ 50 Hz / 1050 W	220 - 240 V ~ 50 Hz / 800 W	220 - 240 V ~ 50 Hz / 600 W
Max. delivery capacity / height	5000 l/h / 50 m	4500 l/h / 48 m	4200 l/h / 43 m	4000 l/h / 36 m
Max. suction height	8 m	8 m	8 m	8 m
Suction connection / pressure connection	42 mm (1 1/4") ET / 33.3 mm (1") IT	42 mm (1 1/4") ET / 33.3 mm (1") IT	42 mm (1 1/4") ET / 33.3 mm (1") IT	42 mm (1 1/4") ET / 33.3 mm (1") IT
Power cord	1.5 m	1.5 m	1.5 m	1.5 m
Product weight	9.7 kg	9.5 kg	8.2 kg	6.1 kg
Carry handle	Comfort	Comfort	Foldable	Foldable
Water filler screw	•	•	•	•
Prefilter with integrated non-return valve	-	-	-	-
Frost protection due to a water drain screw	•	•	•	•
Water filling indicator	•	•	•	•
Thermo protection	•	•	•	•
ECO Power	-	-	•	•
Artikelnummer	41.803.50	41.803.40	41.803.30	41.803.20



ALL-ROUNDERS FOR THE GARDEN.

Einhell garden pumps are useful aids for watering the garden. Water from ponds, water butts or wells are ideally suited to watering lawns or plants, avoiding the use of valuable drinking water resources in the process. Just like all of our other surface pumps, the garden pumps are placed outside the water, which they suck in via a suction hose and pump through a pressure hose/delivery hose to the consumers.

GARDEN PUMPS



	GE-GP 9041 E	GE-GP 5537 E
Mains voltage	230 V ~ 50 Hz	230 V ~ 50 Hz
Rated input	900 W	590 W
Max. delivery capacity / height	4100 l/h / 48 m	3750 l/h / 38 m
Max. suction height	8 m	8 m
Suction connection	33.3 mm (1") IT	33.3 mm (1") IT
Pressure connection	33.3 mm (1") IT	33.3 mm (1") IT
Power cord	1.5 m	1.5 m
Product weight	10.9 kg	7.3 kg
Carry handle	•	•
Water filler screw	•	•
Prefilter with integrated non-return valve	•	•
Frost protection due to a water drain screw	•	•
High-quality mechanical seal	•	•
Suction hose included	-	-
Artikelnummer	41.822.75	41.801.34



EXPERT

EXPERT



GARDEN PUMPS



CLASSIC



CLASSIC



CLASSIC



CLASSIC



NEW

CLASSIC

	GC-GP 1250 N	GC-GP 1046 N	GC-GP 6538	GC-GP 6538 Set	GC-GP 6036
Mains voltage	220 - 240 V ~ 50 Hz	220 - 240 V ~ 50 Hz	220 - 240 V ~ 50 Hz	220 - 240 V ~ 50 Hz	230 V ~ 50 Hz
Rated input	1200 W	1050 W	650 W	650 W	600 W
Max. delivery capacity / height	5000 l/h / 50 m	4600 l/h / 48 m	3800 l/h / 36 m	3800 l/h / 36 m	3600 l/h / 40 m
Max. suction height	8 m	8 m	8 m	8 m	8 m
Suction connection	42 mm (1¼") ET	42 mm (1¼") ET	33.3 mm (1") ET	33.3 mm (1") ET	33.3 mm (1") IT
Pressure connection	33.3 mm (1") IT	33.3 mm (1") IT	33.3 mm (1") ET	33.3 mm (1") ET	33.3 mm (1") IT
Power cord	1.5 m	1.5 m	1.4 m	1.4 m	1.5 m
Product weight	9.8 kg	9.6 kg	6.1 kg	6.1 kg	9.5 kg
Carry handle	•	•	•	•	•
Water filler screw	•	•	•	•	•
Frost protection due to a water drain screw	•	•	•	•	•
High-quality mechanical seal	•	•	•	•	-
Suction hose included	-	-	-	• (7 m)	-
Artikelnummer	41.814.60	41.814.50	41.802.80	41.802.83	41.802.69



AUTOMATIC HOME AND GARDEN PUMPS 'PLUS'

Einhell automatic home and garden pumps 'Plus' have innovative features to make them even more user-friendly than previous automatic home and garden pumps.

Starting up and troubleshooting are even easier than ever before thanks to innovative status indicators such as suction, dirt and water filling indicators. For a long service life, low maintenance and exceptional protection, special safety mechanisms such as the flow sensor, dry running protection, scalding protection and frost protection are included. Like every Einhell pump, they have thermo protection to prevent any damage from overheating of the engine.

AUTOMATIC HOME AND GARDEN PUMPS ,PLUS'

AUTO-MATIC

	NEW	EXPERT	NEW	EXPERT
	GE-AW 1246 N FS		GE-AW 1042 FS	
Mains voltage / rated input	230 V ~ 50 Hz / 1200 W		230 V ~ 50 Hz / 1000 W	
Max. delivery capacity / height / pressure	4600 l/h / 50 m / 5.0 bar		4000 l/h / 48 m / 4.8 bar	
Max. suction height	8 m		8 m	
Suction connection / pressure connection	42 mm (1½") ET / 33.3 mm (1") IT		42 mm (1½") ET / 33.3 mm (1") IT	
Additional pressure connection	33.3 mm (1") IT		33.3 mm (1") IT	
Power cord	1.5 m		1.5 m	
Product weight	14.0 kg		14.0 kg	
Carry handle	Comfort		Comfort	
Water filler screw	•		•	
Prefilter with integrated non-return valve	•		•	
Frost protection due to a water drain screw	•		•	
Indicator	LCD		LED	
Water filling / dirt / suction indicator	• / • / •		• / • / •	
Thermo / scalding protection	• / •		• / •	
Dry running protection	•		•	
Water flow recognition sensor	•		•	
Automatic / timer function	• / •		• / -	
Artikelnummer	41.770.20		41.770.10	



NEW



NEW



4 006825 642476



4 006825 642469



THE COMPLETE SUPPLY PACKAGE – FOR THE HOUSE AND THE GARDEN.

Einhell automatic home and garden pumps are perfect for house and garden: Whether for automatic domestic water supplies to provide service water for toilet flushing or washing machines or for automatic garden watering – this is no problem at all.

But what is the difference to a standard garden pump? An integrated flow switch automatically switches the pump on when a water demand is present and then off again, allowing this type of pump to be used fully-automatically for domestic water supplies or for garden watering tasks, reducing the demand for valuable drinking water resources in the process.



AUTOMATIC HOME AND GARDEN PUMPS



	GE-AW 9041 E	GE-AW 5537 E
Mains voltage	230 V ~ 50 Hz	230 V ~ 50 Hz
Rated input	900 W	590 W
Max. delivery capacity / height / pressure	4100 l/h / 48 m / 4.8 bar	3750 l/h / 38 m / 3.8 bar
Max. suction height	8 m	8 m
Suction connection	33.3 mm (1") IT	33.3 mm (1") IT
Pressure connection	33.3 mm (1") IT	33.3 mm (1") IT
Power cord	1.5 m	1.5 m
Product weight	11.9 kg	7.8 kg
Carry handle	•	•
Water filler screw	•	•
Prefilter with integrated non-return valve	•	•
Frost protection due to a water drain screw	•	•
Indicator	LED	LED
Dry running protection	•	•
Automatic /timer function	• / -	• / -
ECO Power	•	•
Artikelnummer	41.770.04	41.766.54



4 006825 587289



4 006825 587258

AUTOMATIC HOME AND GARDEN PUMPS



DRY RUNNING
PROTECTION



CLASSIC



CLASSIC



CLASSIC

	GC-AW 1136	GC-AW 9036	GC-AW 6333
Mains voltage	230 V ~ 50 Hz	230 V ~ 50 Hz	230 V ~ 50 Hz
Rated input	1100 W	900 W	630 W
Max. delivery capacity / height / pressure	3600 l/h / 46 m / 4.6 bar	3600 l/h / 43 m / 4.3 bar	3300 l/h / 36 m / 3.6 bar
Max. suction height	7 m	7 m	8 m
Suction connection	42 mm (1½") ET	42 mm (1½") ET	42 mm (1½") ET
Pressure connection	33.3 mm (1") IT	33.3 mm (1") IT	33.3 mm (1") IT
Power cord	1.5 m	1.5 m	1.5 m
Product weight	10.7 kg	9.9 kg	7.8 kg
Carry handle	•	•	•
Water filler screw	•	•	•
Prefilter with integrated non-return valve	•	•	•
Frost protection due to a water drain screw	•	•	•
Indicator	LCD	LED	LED
Dry running protection	•	•	•
Automatic /timer function	• / •	• / -	• / -
ECO Power	-	-	-
Artikelnummer	41.767.16	41.767.20	41.767.30



WATER WORKS 'PLUS'

Einhell water works 'Plus' have innovative features to make them even more user-friendly than previous domestic water works.

Starting up and troubleshooting are even easier than ever before thanks to innovative status indicators such as suction, dirt and water filling indicators. For a long service life, low maintenance and exceptional protection, some models have special safety mechanisms such as the flow sensor, dry running protection, scalding protection and frost protection. But every model has a thermo switch for protection against damage caused by overheating of the engine.



WATER WORKS ,PLUS'



SPRING 2020



NEW

EXPERT

SPRING 2020



NEW

EXPERT



NEW

CLASSIC



NEW

CLASSIC

	GE-WW 1246 N FS	GE-WW 1145 ECO	GC-WW 1045 N	GC-WW 8042 ECO
Mains voltage / rated input	220 - 240 V ~ 50 Hz / 1200 W	220 - 240 V ~ 50 Hz / 1100 W	220 - 240 V ~ 50 Hz / 1050 W	220 - 240 V ~ 50 Hz / 800 W
Max. delivery capacity / height / suction height	4600 l/h / 50 m	4500 l/h / 48 m	4500 l/h / 48 m	4200 l/h / 43 m
Max. suction height	8 m	8 m	8 m	8 m
Suction connection / pressure connection	42 mm (1½") ET / 33.3 mm (1") IT	42 mm (1½") ET / 33.3 mm (1") IT	42 mm (1½") ET / 33.3 mm (1") IT	42 mm (1½") ET / 33.3 mm (1") IT
Additional pressure connection	33.3 mm (1") IT	33.3 mm (1") IT	-	-
Tank volume	20 l	20 l	20 l	20 l
Max. activation / cut off pressure	1.5 bar / 3 bar	1.5 bar / 3 bar	1.5 bar / 3 bar	1.5 bar / 3 bar
Product weight	19.5 kg	19.5 kg	17.3 kg	13.3 kg
Carry handle	Comfort	Comfort	Comfort	Foldable
Water filler screw	•	•	•	•
Prefilter with integrated non-return valve	•	•	-	-
Frost protection due to a water drain screw	•	•	•	•
Water filling / dirt / suction indicator	• / • / •	• / • / •	• / - / -	• / - / -
Thermo / scalding protection	• / •	• / -	• / -	• / -
Dry running protection	•	-	-	-
Water flow recognition sensor	•	-	-	-
Pressure gauge	•	•	•	•
ECO Power	-	•	-	•
Artikelnummer	41.735.30		41.735.20	41.735.10



4 006825 640373

Article number and +
EAN code not yet specified.



4 006825 637304



4 006825 637298

DOMESTIC WATER SUPPLIES **MADE EASY.**

Einhell domestic water works are not only quiet and environmentally friendly, but they also represent a cost-effective alternative to domestic water supplies with drinking water. They enable clean water to be delivered from reservoirs, wells and shafts for use as service water in irrigation systems, washing equipment, toilet flushing systems and much more besides. The pressure vessel offers a capacity of 20 litres, so the pump does not need to start up every time water is drawn off.

An integrated pressure switch will activate the pump when the pressure drops and deactivate it again when the pressure returns to maximum. On the integrated pressure gage you can read off the pressure at a glance.

WATER WORKS



	GE-WW 9041 E	GE-WW 5537 E
Mains voltage / rated input	230 V ~ 50 Hz / 900 W	230 V ~ 50 Hz / 590 W
Max. delivery capacity / height	4100 l/h / 48 m	3750 l/h / 38 m
Max. suction height	8 m	8 m
Max. activation / cut off pressure	1.5 bar / 3 bar	1.5 bar / 3 bar
Tank volume	20 l	20 l
Suction connection	33.3 mm (1") IT	33.3 mm (1") IT
Pressure connection	33.3 mm (1") IT	33.3 mm (1") IT
Product weight	16.6 kg	11.9 kg
Carry handle	•	•
Water filler screw	•	•
Prefilter with non-return valve	•	•
Frost protection due to a water drain screw	•	•
High-quality mechanical seal	•	•
Pressure gauge	•	•
Suction hose included	-	-
Artikelnummer	41.734.44	41.731.75



WATER WORKS



CLASSIC



CLASSIC



CLASSIC



CLASSIC



NEW

CLASSIC

	GC-WW 1250 NN	GC-WW 1046 N	GC-WW 6538	GC-WW 6538 Set	GC-WW 6036
Mains voltage / rated input	220 - 240 V ~ 50 Hz / 1200 W	220 - 240 V ~ 50 Hz / 1050 W	220 - 240 V ~ 50 Hz / 650 W	220 - 240 V ~ 50 Hz / 650 W	230 V ~ 50 Hz / 600 W
Max. delivery capacity / height	5000 l/h / 50 m	4600 l/h / 48 m	3800 l/h / 36 m	3800 l/h / 36 m	3600 l/h / 40 m
Max. suction height	8 m	8 m	8 m	8 m	8 m
Max. activation / cut off pressure	1.5 bar / 3 bar	1.5 bar / 3 bar	1.5 bar / 3 bar	1.5 bar / 3 bar	1.5 bar / 3 bar
Tank volume	20 l	20 l	20 l	20 l	20 l
Suction connection	42 mm (1 1/4") ET	42 mm (1 1/4") ET	33.3 mm (1") ET	33.3 mm (1") ET	33.3 mm (1") IT
Pressure connection	33.3 mm (1") IT	33.3 mm (1") IT	33.3 mm (1") ET	33.3 mm (1") ET	33.3 mm (1") IT
Product weight	14.7 kg	14.4 kg	10.5 kg	10.5 kg	14.3 kg
Carry handle	-	-	-	-	-
Water filler screw	•	•	•	•	•
Prefilter with non-return valve	-	-	-	-	-
Frost protection due to a water drain screw	•	•	•	•	•
High-quality mechanical seal	•	•	•	•	-
Pressure gauge	•	•	•	•	•
Suction hose included	-	-	-	• (7 m)	-
Artikelnummer	41.734.90	41.734.80	41.731.90	41.731.93	41.731.18



FULL POWER – WITHOUT ANY ELECTRICITY AT ALL.

With Einhell petrol water pumps, you are always independent of a mains power supply – whether on a camping trip or working in your allotment. The petrol-powered water pumps are suitable not only for harsh, high-performance applications for mains supply-independent water supply tasks, but also for numerous permanent drainage tasks. Thanks to the low-consumption pump technology, these pumps are ideally suited to numerous permanent drainage and watering tasks.

PETROL WATER PUMPS



	GE-PW 46	GC-PW 16
Motor	Four-stroke	Four-stroke
Power rating	4.6 / 6.3	1.6 / 2.2
Max. delivery capacity / height	23000 l/h / 26 m	12000 l/h / 20 m
Max. suction height	6.5 m	6.5 m
Max. speed	3600 min ⁻¹	3800 min ⁻¹
Suction connection	59.6 mm (2") ET	47.8 mm (1½") ET
Pressure connection	59.6 mm (2") ET	47.8 mm (1½") ET
Fuel tank capacity	3.6 l	1.4 l
Product weight	23.0 kg	11.2 kg
Sturdy steel tube frame	•	–
Water filler port	•	•
Water drain screw	•	•
Oil filling screw	•	•
Low oil stop	•	•
Accessories Set for GC-PW 16	–	•
Accessories Set for GE-PW 46	•	–
Artikelnummer	41.713.72	41.905.30





ACCESSORIES SET GE-PW 46

- 2x adapters 50.8 mm (2") (hose connector)
- 2x adapters 33.3 mm (R1) ET (thread connector)
- 2x adapters 47.8 mm (R1½) ET (thread connector)
- 1x strainer 50.8 mm (2") (hose connector)

Included with the GE-PW 46 –
not available separately as an accessory!



ACCESSORIES SET GC-PW 16

- 2x hose adapters 38.1 mm (1.5")
- 1x strainer 38.1 mm (1.5") (hose connector)
- 2x reducers onto 33.3 mm (R1") external thread

Included with the GC-PW 16 –
not available separately as an accessory!



SURFACE PUMPS ACCESSORIES



	Suction Hose	Suction Hose	Suction Hose	Suction Hose
Length	4 m	4 m	7 m	7 m
Connectors material	Brass	Plastic	Brass	Plastic
Connectors	42 mm (1¼") IT	42 mm (1¼") IT	42 mm (1¼") IT	42 mm (1¼") IT
Hose diameter	25 mm (1")	25 mm (1")	25 mm (1")	25 mm (1")
Threaded nipple	33.3 mm (1¼") ET	33.3 mm (1¼") ET	33.3 mm (1¼") ET	33.3 mm (1¼") ET
Adapter	-	33.3 mm (1¼") IT	-	33.3 mm (1¼") IT
Artikelnummer	41.736.30	41.736.35	41.736.40	41.736.45



SURFACE PUMPS ACCESSORIES



	Coarse Filter	Coarse Filter
Height of filter insert	12 cm	25 cm
Brass connection	33.3 mm (1") IT	33.3 mm (1") IT
Max. working pressure	5.5 bar	5.5 bar
Max. delivery quantity	4300 l/h	4000 l/h
Cartridge included	•	•
Connector	33.3 mm (1") ET / 42 mm (1 1/4") IT	33.3 mm (1") ET / 42 mm (1 1/4") IT
Double nipple	33.3 mm (1") ET	33.3 mm (1") ET
Cartridge included	•	•
Artikelnummer	41.738.01	41.738.51



SURFACE PUMPS ACCESSORIES



	Electronic Flow Switch
Brass connection	33.3 mm (1") IT
Power cord	1.45 m
Non-return valve	•
Connection-adapter	33.3 mm (1") ET / 33.3 mm (1") ET
Dry running protection	•
Artikelnummer	41.742.21



SURFACE PUMPS ACCESSORIES
 HOSES MISCELLANEOUS



Electronic Flow Switch	41.742.21		AQUINNA	GE-GP 1246 N FS	GE-GP 1145 ECO	GC-GP 1250 N	GC-GP 1045	GC-GP 8042 ECO	GC-GP 6040 ECO	GE-GP 9041 E	GE-GP 5537 E	GC-GP 1250 N	GC-GP 1046 N	GC-GP 6538	GC-GP 6036
Coarse Filter 12 cm with Cartridge	41.738.01		•			•	•	•	•			•	•		•
Coarse Filter 25 cm with Cartridge	41.738.51		•			•	•	•	•			•	•		•
Suction Hose 4 m with Brass Connections	41.736.30		•	•	•	•	•	•	•	•	•	•	•		•
Suction Hose 4 m with Plastic Connections	41.736.35		•	•	•	•	•	•	•	•	•	•	•	•	•
Suction Hose 7 m with Brass Connections	41.736.40		•	•	•	•	•	•	•	•	•	•	•		•
Suction Hose 7 m with Plastic Connections	41.736.45		•	•	•	•	•	•	•	•	•	•	•	•	•



BMW i Motorsport
Official Partner



PUMPING MADE EASY. WATER TECHNOLOGY FOR HOUSE AND GARDEN.



Einhell Germany AG

Wiesenweg 22
94405 Landau/Isar
Germany

info@einhell.de
www.einhell.de

Service:

Einhell Service

Eschenstr. 6
94405 Landau/Isar
Germany

Service-DE@einhell.com
www.einhell-service.com

einhell.de

>>>